

**TANGO 32 (TA-31891)**

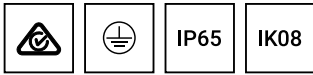

**Product description**

186x186 mm - 290 mm - Down (Optic)  
& Up (Optic 2nd) - Square



**Luminaire structure**

- Die-cast aluminium housing and frame
- Pre-treated before powder coating ensuring high corrosion resistance
- Single cable entry
- Stainless steel fasteners in grade 304 with zinc flake coating (ZFC)
- Durable silicone rubber gasket
- Clear toughened glass
- High-efficiency optical reflector
- Integral control gear
- Optional surface mounting box for easy wiring or conduit connection when wiring from behind is not possible

**Light symbol**



**Product colour**



**Special finishes upon request**

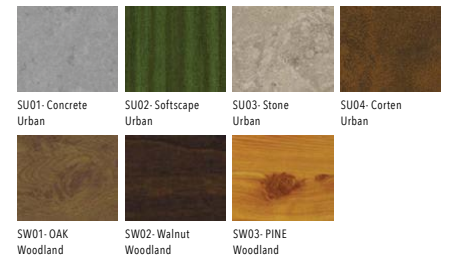

**Technical information**

Light source	16 & 16 LED
Light source type	LED
Dimming type	DALI, On/Off
Material	Aluminium
Weight	6.4 kg
Operating temperature	-20°C to 40°C

<b>Luminaire</b>	
Power	35 & 70 W
Lumen	3476 - 7820 lm
Efficacy	99 - 112 lm/W
CCT / CRI	3000K, 4000K
Drive current	350 & 700 mA
Driver option	Integral control gear
Driver	Constant current (CC)
Input voltage	220-240 V 50/60 Hz

Optic	T2 [139°x52°], T3 [129°x69°], T4 [102°x78°], LA01 [151°x65°]
Optic (Up)	T2 [139°x52°], T3 [129°x69°], T4 [102°x78°], LA01 [151°x65°]
Bug	B1-U5-G1
ULR	49%, 50%, 51%
ULOR	49%, 50%, 51%
CIE flux code n°3	98
MacAdam Ellipse	3 SDCM
Lifetime L90B10 (hrs)	90,000
Lifetime L80B10 (hrs)	90,000
Lifetime L80B50 (hrs)	90,000

TANGO 32 (TA-31891)

Product variants

HOW TO SPECIFY

MODEL	OUTPUT	DISTRIBUTION		CRI/CCT	DIMMING	COLOUR FINISH
<b>DOWN - UP</b>						
TA-31891	350 35W	T2	T2	8030	ND	01 BLACK
	700 70W	T3	T3	8040	DALI	02 DARK GREY
		T4	T4			03 WHITE
		LA01	LA01			05 MATT SILVER
					06 BRONZE	
						S - SPECIAL FINISH

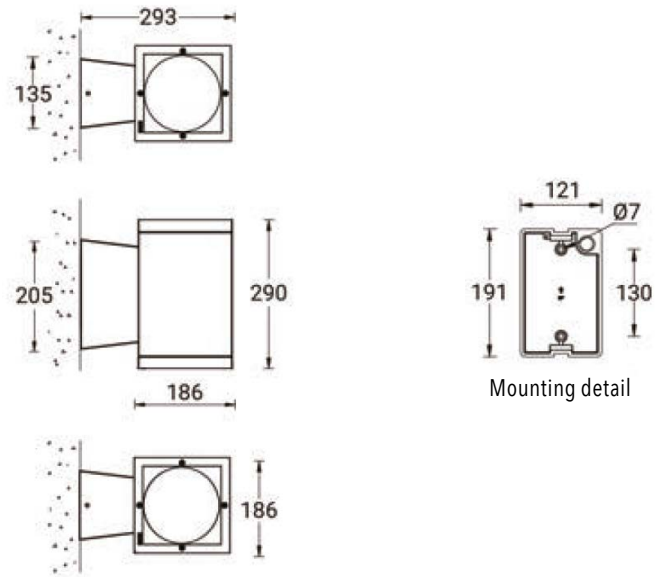

Accessories



Surface mounting box for easy cabling (TANGO 32)  
LIGA-SCE-TANGO-32